

Raychem

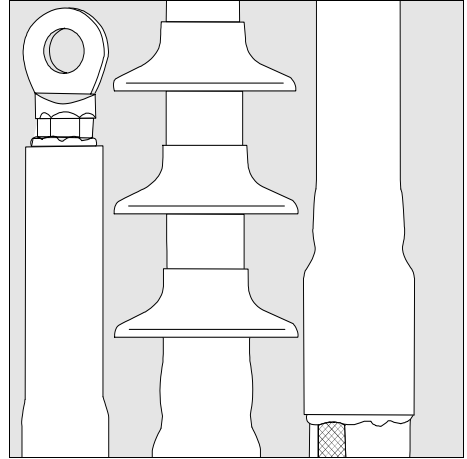

**Installation Instruction
EPP-0275-12/02**

**Terminations for
Screened Single Core
Polymeric
Insulated Cables
7.2 kV to 36 kV
without Armour**

Tyco Electronics Raychem GmbH
Energy Division
Finsinger Feld 1
85521 Ottobrunn
Munich, Germany
Tel. ++49-89-6089-0
Fax ++49-89-6096345

Before Starting

Check to ensure that the kit you are going to use fits the cable.

Refer to the kit label and the title of the installation instruction.

Components or working steps may have been improved since you last installed this product.

Carefully read and follow the steps in the installation instruction.

General Instructions

Use a propane (preferred) or butane gas torch.

Ensure the torch is always used in a well-ventilated environment.

Adjust the torch to obtain a soft blue flame with a yellow tip.

Pencil-like blue flames should be avoided.

Keep the torch aimed in the shrink direction to preheat the material.

Keep the flame moving continuously to avoid scorching the material.

Clean and degrease all parts that will come into contact with adhesive.

If a solvent is used follow the manufacturer's handling instructions.

Tubing should be cut smoothly with a sharp knife leaving no jagged edges.

Start shrinking the tubing at the position recommended in the instruction.

Ensure that the tubing is shrunk smoothly all around before continuing along the cable.

Tubing should be smooth and wrinkle free with inner components clearly defined.

The Information contained in these installation instructions is for use only by installers trained to make electrical power installations and is intended to describe the correct method of installation for this product. However, Tyco Electronics has no control over the field conditions which influence product installation.

It is the user's responsibility to determine the suitability of the installation method in the user's field conditions. Tyco Electronics' only obligations are those in Tyco Electronics' standard Conditions of Sale for this product and in no case will Tyco Electronics be liable for any other incidental, indirect or consequential damages arising from the use or misuse of the products.

Raychem is a trade mark.

Cable Preparation

A Cable with wire shield

Table 1

Max. system voltage [kV]	L	L	K
	indoor [mm]	outdoor [mm]	
7,2	150	200	according
12/17.5	230	300	to depth of
24	270	350	connector barrel
36	370	500	hole + 5 mm

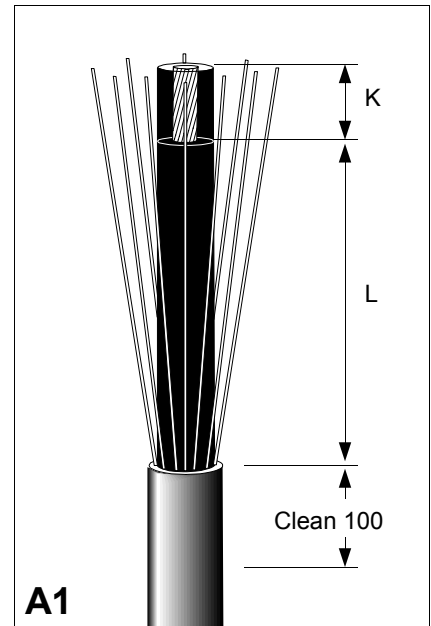

A1 Cut the cable to the required length. Remove the overshath to the dimension L + K (Table 1). Clean and degrease the end of the overshath for about 100 mm.

Wrap one layer of sealant tape (red) with a small overlap and slight tension around the end of the overshath for 60 mm. Bend the shielding wires back onto the overshath. Avoid crossing the individual wires. Fix the wires with a wire binder 60 mm from the end of the overshath. Gather the shielding wires together to form an earth lead.

Thoroughly remove the core screen to within 40 mm of the overshath cut. The surface of the insulation should be free from all traces of conductive material. Smooth out any irregularities.
Note: Do not nick the insulation.

Remove the release paper and wrap the void filling strip (yellow) around the end of the core screen. Cover 20 mm of the core screen and continue onto the insulation for 10 mm. Stretch the strip to half of its original width to achieve a fine, thin edge onto the insulation.

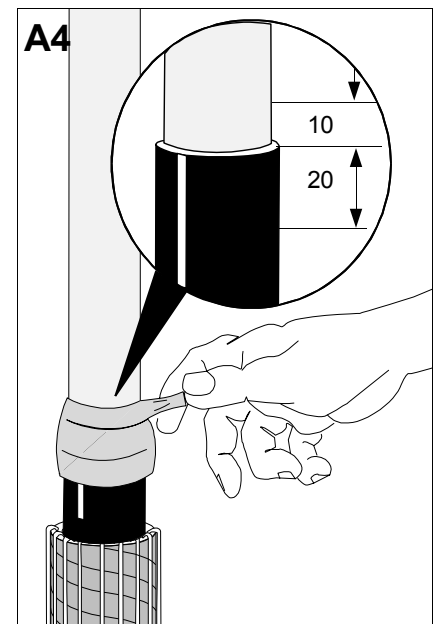
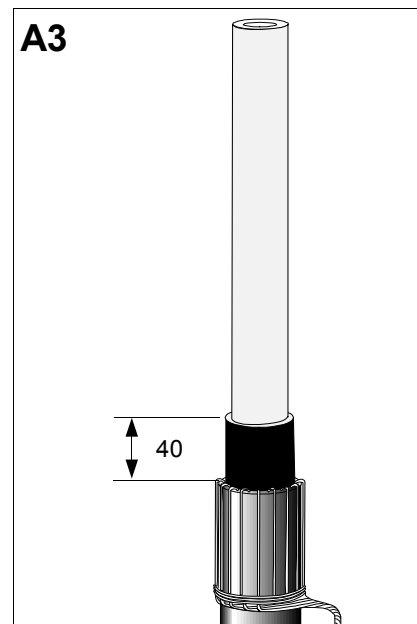
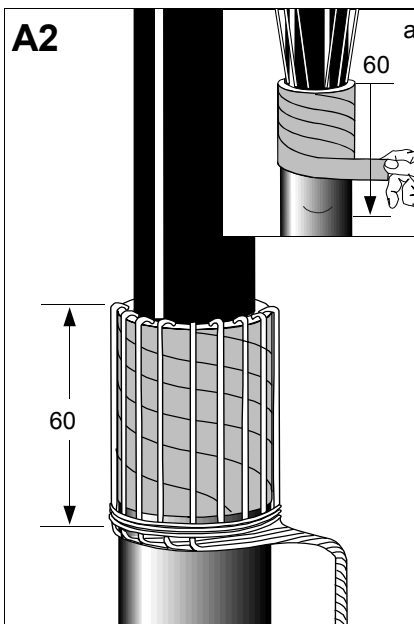

B Cable with metal tape shield

Table 2

Max. system voltage [kV]	L	L	K
	indoor [mm]	outdoor [mm]	
7,2	150	200	according
12/17.5	230	300	to depth of
24	270	350	connector barrel
36	370	500	hole + 5 mm

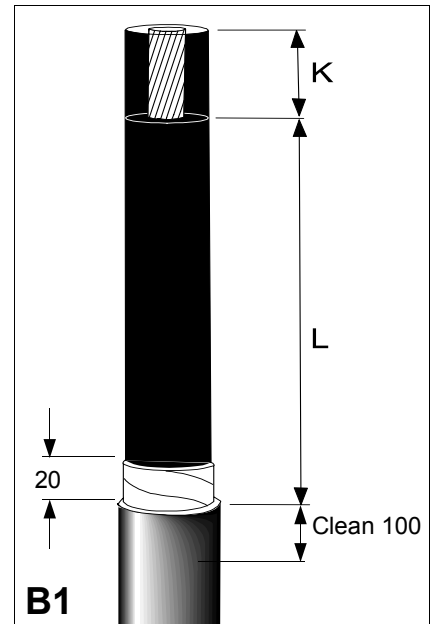

Cut the cable to the required length. Remove the oversheath to the dimension L + K (Table 2). Clean and degrease the end of the oversheath for about 100 mm. Remove the metal tape shield to within 20 mm of the oversheath cut.

Wrap one layer of sealant tape (red) with a small overlap and slight tension round the end of the oversheath for 60 mm. Bind and solder tack an earth lead to the metal tape shield (or attach the earth lead by any other equivalent method). Fill the earth lead with solder to form a 30 mm moisture block 20 mm from the oversheath end. Fix the earth braid with a second wire binder 60 mm from the end of the oversheath.

Thoroughly remove the core screen to within 40 mm of the oversheath cut. The surface of the insulation should be free from all traces of conductive material. Smooth out any irregularities.

Note: Do not nick the insulation.

Remove the release paper and wrap the void filling strip (yellow) around the end of the tape shield. Cover 5 mm of the tape shield and continue along the core screen onto the insulation for 10 mm. Stretch the strip to half of its original width to achieve a fine, thin edge onto the insulation.

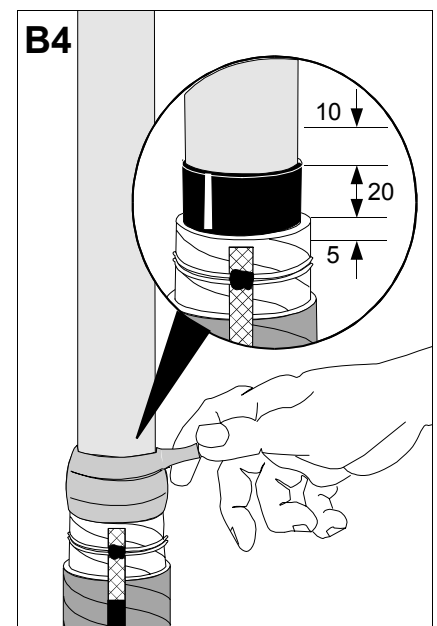
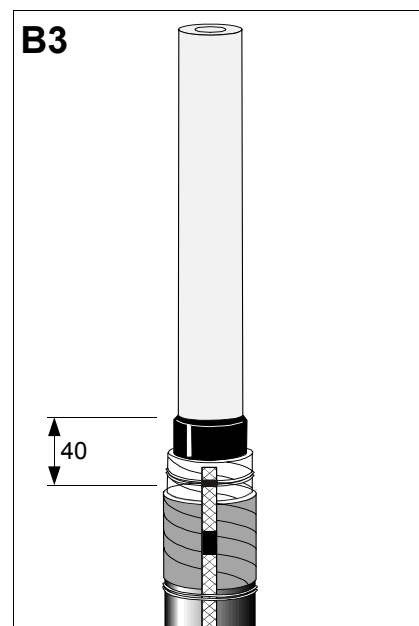
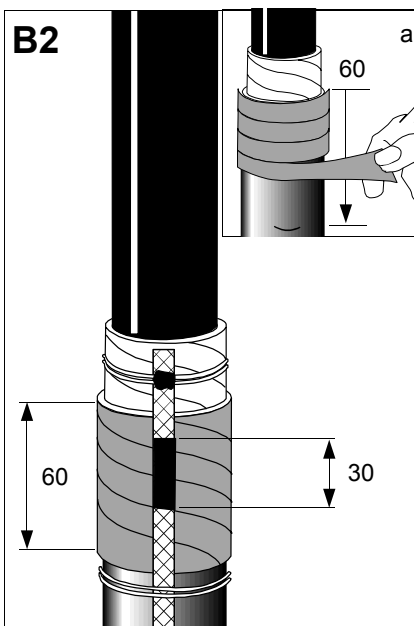

Completion of Termination

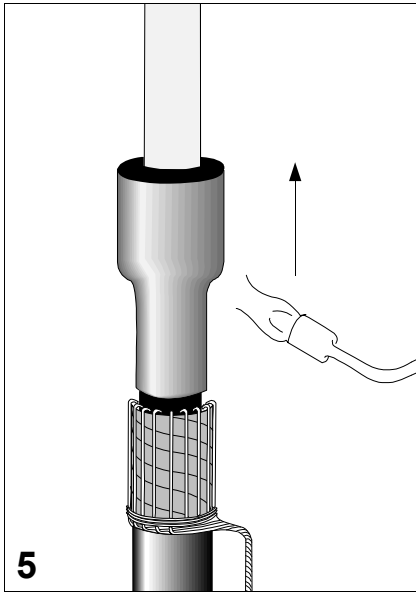

Place the stress control tubing (black) over the core and position it so that it is level with the oversheath cut. Shrink the tubing down starting at the bottom and working towards the core end.

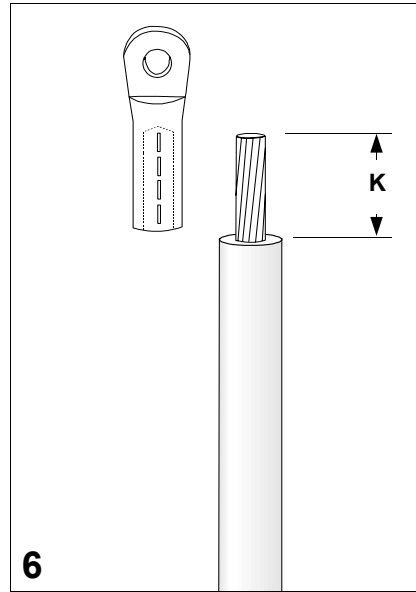

Cut back the insulation according to dimension $K = \text{depth of cable lug barrel hole} + 5 \text{ mm}$. Install the cable lug. Clean and degrease the insulation and the lug.

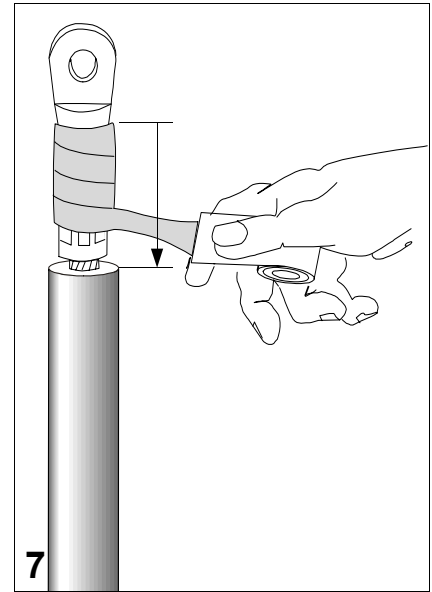

Wrap the red sealant tape around the barrel of the cable lug. Stretch the tape to half of its width and apply with half overlap. **Note:** Use the remaining sealant (red) to fill any remaining gap between the core insulation and the cable lug.

Remove the release paper from the tubing (red). Place the tubing with the sealant coated end downwards over the core, level with the wire binder. Shrink the tubing down starting at the oversheath end, working towards the cable lug.

Cut the tubing back onto the cable lug barrel if necessary. **Note:** For cross sections above 120 mm^2 . Postheat the palm of the cable lug until a bead of sealant appears around the top of the tubing. **Indoor termination up to 17.5 kV completed.** Allow the termination to cool before applying any mechanical strain.

For indoor terminations above 17.5 kV and all outdoor terminations shrink the skirts into place at the positions shown in the drawing on the next page.

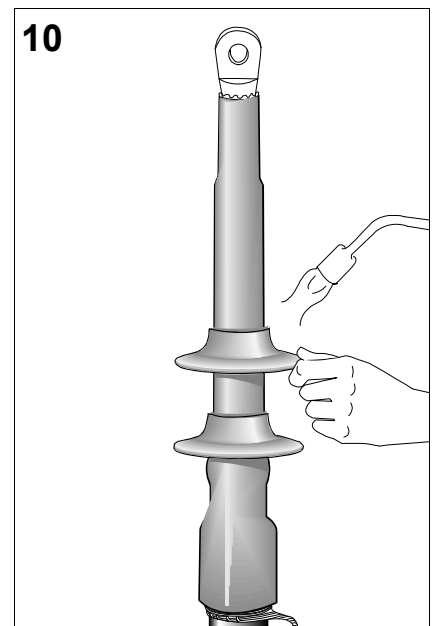
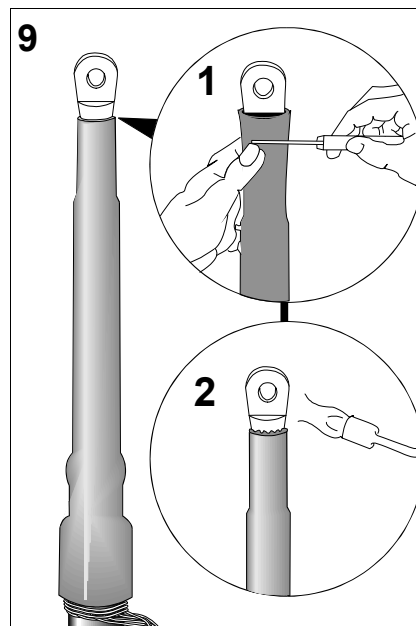
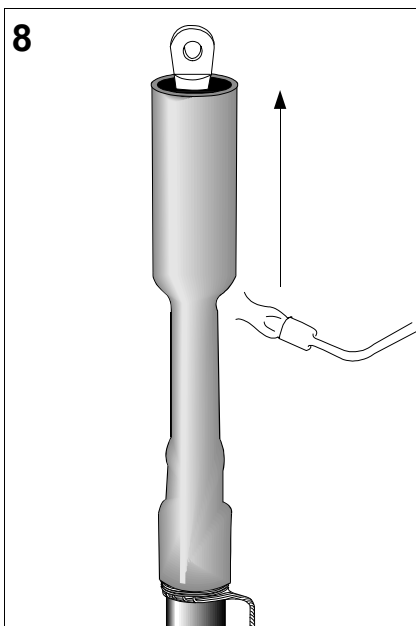

indoor

outdoor

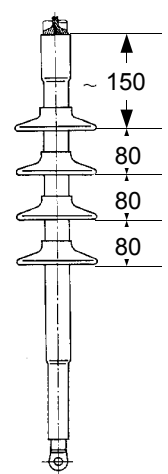
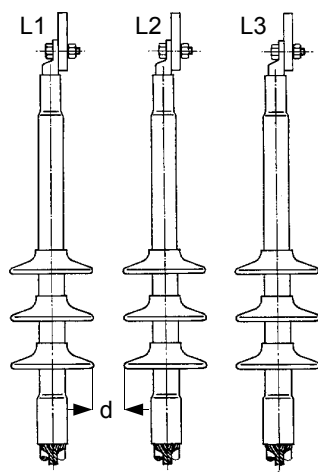
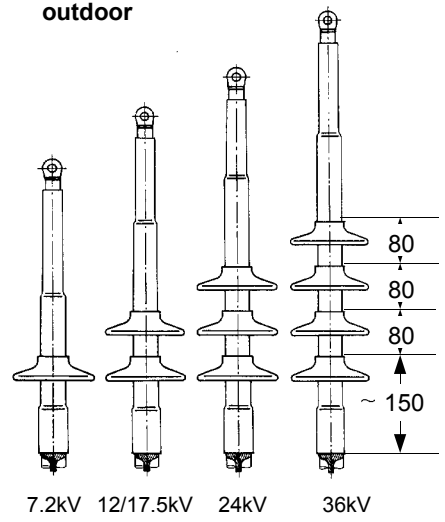
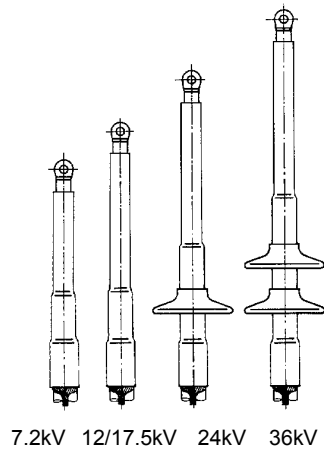

skirt position
for reversed
installation

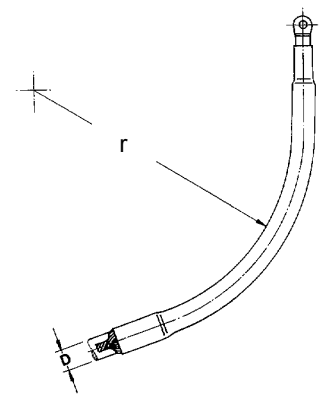
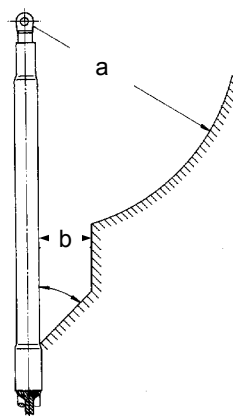

Min. clearances		Max. system voltage (kV)				
		7,2	12	17,5	24	36
a	air clearance	as for local specifications				
b	ph/ground [mm]	10	15	20	25	35
d	between skirts [mm]	10	10	15	20	25
r	min. bending radius = 15xD, before bending heat cable up to approx. 70°C					

Please dispose of all waste according to environmental regulations.

